

RBM

ROD END BEARING FEMALE MOLDED MINELON TN

Materials

BODY Low Carbon Steel / Zinc Plated
BALL Bearing Steel / Heat Treated / Chrome Plated
LINER Minelton

Description of Types

RBM L xx
 Bearing Bore Code
 No Letter Indicates right hands
 Letter "L" Indicates left hands
 Basic Part No.

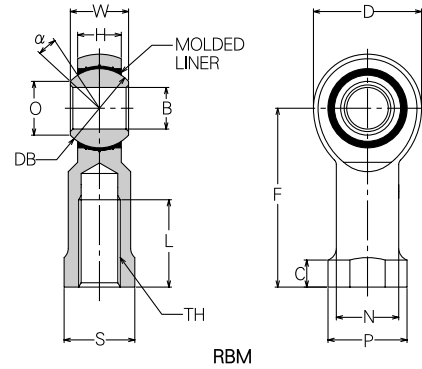

Dimensions in mm

MINEBEA Part No.	ϕB H7	ϕD ± 0.5	W 0 -0.13	H ± 0.13	F ± 0.5	TH JIS Class 2	L ± 0.7	ϕN ± 0.5	ϕP ± 0.5	C + 0.2 - 0.7	S ± 0.25	α (deg.)	ϕO Ref.	S ϕDB Ref.	No Load Rotational Breakaway Torque N · m	Radial Clearance mm	Radial Static Limit Load kN	Dynamic Load kN	Approx. Weight g
RBM5	5	16	8	6.00	27	M5 × 0.8	14	9.0	11	4.0	9	13	7.7	11.11	0.04MAX	0.03MAX	5.98	1.90	16
RBM6	6	18	9	6.75	30	M6 × 1.0		10.0	13	5.0	11		9.0	12.70	[0.4kgf · cmMAX]			7.55	2.17
RBM8	8	22	12	9.00	36	M8 × 1.25	17	12.5	16		14	14	10.4	15.88	0.06MAX	0.05MAX	10.29	3.48	45
RBM10	10	26	14	10.50	43	M10 × 1.5	21	15.0	19		17	14	12.9	19.05	[0.6kgf · cmMAX]			14.61	5.14
RBM12	12	30	16	12.00	50	M12 × 1.75	24	17.5	22	6.5	19	13	15.4	22.22	0.12MAX [1.2kgf · cmMAX]		18.14	6.52	120
RBM14	14	34	19	13.50	57	M14 × 2.0	27	20.0	25	8.0	22	16	16.9	25.40	0.34MAX [3.5kgf · cmMAX]	0.05MAX	24.02	8.72	160
RBM16	16	38	21	15.00	64	M16 × 2.0	33	22.0	27		27			19.4			28.58		
RBM18	18	42	23	16.50	71	M18 × 1.5	36	25.0	31	10.0	27	15	21.9	31.75	0.57MAX [5.8kgf · cmMAX]		35.79	13.23	300
RBM20	20	46	25	18.00	77	M20 × 1.5	40	27.5	34				30			24.4	34.92		
RBM22	22	50	28	20.00	84	M22 × 1.5	43	30.0	37	12.0	32		25.9	38.10			50.01	18.73	480

Notes

- Operating temperature range: - 50 ~ + 100 °C
- Dynamic Load Ratings: Cd
 - Reversing & Alternating Load
Dynamic Load Ratings shall be reduced by half from the values given in the table under the use of reversing and alternating load condition.
 - Factor of Operating Temperature and Sliding Speed
Dynamic Load Ratings shall be determined by formula below under the use of High-Temperature and Sliding-Speed condition.
 $Cdt \cdot v = ft \cdot fv \cdot Cd$
 Cdt · v: Dynamic Load Ratings under the use of High-Temperature and Sliding speed.
 ft: Coefficient of Temperature
 fv: Coefficient of Sliding speed

- Static Load Ratings: Cs
 - Dynamic Load Ratings shall be reduced to one-thirds of the values given in the table under the use of that High-Load will be applied continuously or periodically and be reduced to one-sixth of the values given under Reversing and Alternating Load and Impact Load conditions.
 - Factor of Operating Temperature
Dynamic Load Ratings shall be determined by formula below under the use of High-Temperature conditions.
 $Cs \cdot t = ft \cdot Cs$
 Cs · t: Dynamic Load Ratings under the use of High-Temperature condition.
 ft: Coefficient of Temperature
 Cs: Static Load given in the table

Table 1

Temp. °C	~ 40	~ 60	~ 80	~ 100
ft	1.0	0.95	0.8	0.6

Table 2

Sliding Speed m/min	~ 0.3	~ 0.4	~ 0.5	~ 0.6	~ 0.7	~ 0.8	~ 0.9	~ 1.1	~ 1.5	~ 2.5
fv	1	0.9	0.8	0.7	0.6	0.5	0.4	0.3	0.2	0.1

Table 3

Temp. °C	~ 30	~ 40	~ 60	~ 80	~ 90	~ 100
ft	1.0	0.95	0.85	0.6	0.5	0.3

○ Please consult MINEBEA for availability of bearings in this series.

Bore size	~ 3	~ 6	~ 10	~ 18	~ 30
H7 Tolerance (μm)	+ 10 0	+ 12 0	+ 15 0	+ 18 0	+ 21 0