

11338JH (4515JL-GFO)

113[□]X36^L

DC Axial Fan



Taslak Çizim Outline

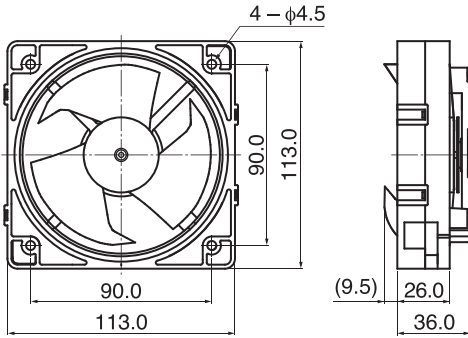

Karakteristik Eğriler Characteristic Curves

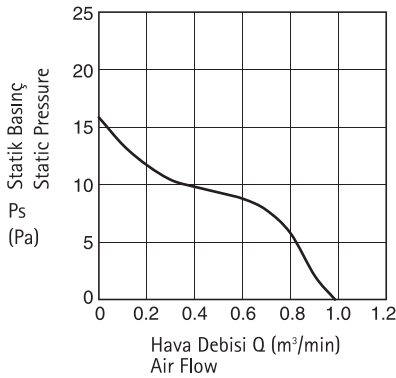

Özellikler Specifications

Model	Ürün No. Product No.	Nominal Gerilim	Çalışma Gerilimi	Akım	Giriş Gücü	Hız	Maks. Hava Debisi	Maks. Statik Basınç	Gürültü	Ağırlık
		Rating Voltage	Operating Voltage	Current	Input Power	Speed	Max. Air Flow	Max. Static Pressure	Noise	Mass
		(V)	(V)	(A)*1	(W)*1	(min ⁻¹)*1	(m³/min)*1 (CFM)*1	(Pa)*1 (In H ₂ O)*1	(dB)*1	(g)
11338JH-09K-BA	F0	9	7.0 ~ 14.0	0.10	0.90	1920	0.94 33.2	15.9 0.06	29.0	190

Dönme Yönü : Saat yönü (Etiket tarafında görüldüğü gibi)
Hava Akımı : Etiket tarafı

Rotation : Clockwise as seen from the label side
Airflow Outlet : Label side

*1: Ortalama değer (Serbest hava)
*1: Average Values in Free Air

Genel Özellikler General Specifications

Motor Koruması : Kilitli Rotor Koruması
Yalıtım Direnci : 10 MΩ veya DC500V Megger üzeri
Dielektrik (Yalıtım) Dayanım Gerilimi : AC600V 1s
İzin Verilen Ortam Sıcaklığı : -40°C ~ +40°C (Operasyon)
-40°C ~ +70°C (Depolama)
(Yoğuşmasız Ortam)

Motor Protection : Locked Rotor Protection
Insulation Resistance : 10MΩ or over with a DC500V Megger
Dielectric Withstand Voltage : AC600V 1s
Allowable Ambient : -40°C ~ +40°C (Operation)
Temperature Range : -40°C ~ +70°C (Storage)
(non-condensing environment)

Tahmini Ömür ※ Hata Oranı : 10% (L10 Life) Expected Life ※ Failure Rate : 10% (L10 Life) -20°C 70,000 Saat (Hours)

Panel Detayı Panel Out-cuts

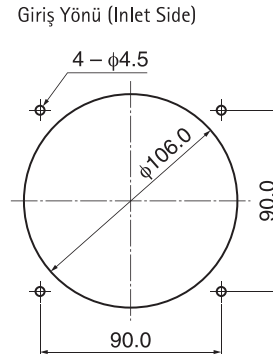

Malzeme Material

Kasa : Plastik (Siyah) UL94V-0
Pervane : Plastik (Siyah) UL94HB
Rulman : Burçlu Rulman
Ana Kablo : UL1007 AWG26 + : Kırmızı, - : Siyah
Casing : Plastic (Black) UL94V-0
Impeller : Plastic (Black) UL94HB
Bearing : Sleeve Bearing
Lead Wire : UL1007 AWG26 + : Red, - : Black

DC FAN

Genel Özellikler

F A

Server

Soğutucu

Blower