

71 \circ 1.8 \circ

29SM-K

1.8 \circ

■ 外観図 Outline

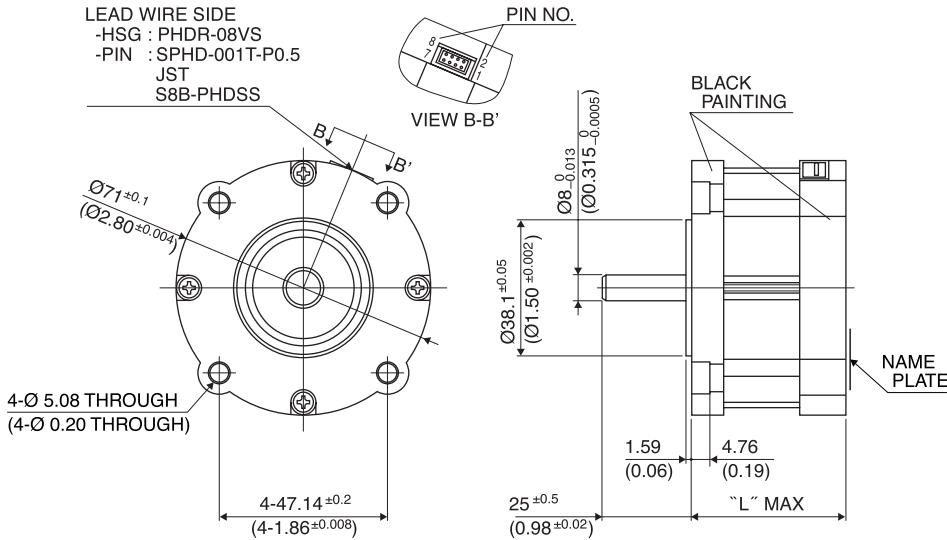

Hybrid

結線表 PIN NO. vs. PHASE

相 (PHASE)	A	A COM	\bar{A}	B	B COM	\bar{B}
ピン番号 (PIN NO.)	3	1	2	8	7	5

	"L"
29SM-K5**	39.5 (1.56)
29SM-K2**	43.5 (1.71)
29SM-K3**	51.5 (2.03)
29SM-K0**	55.5 (2.19)
29SM-K1**	67.5 (2.66)
29SM-K7**	77.5 (3.05)

■仕様 Specifications

型式	ステップ角	ドライブ方式	定格電流	巻線抵抗	ホールディングトルク	インダクタンス	ロータイナーシャ	デイトメントルク	質量
Model	Step Angle	Drive Sequence	Rated Current	Resistance	Holding Torque	Inductance	Rotor Inertia	Detent Torque	Mass
	(deg)		(A)	(Ohms)	(mNm)	(mH)	(g·cm ²)	(mNm)	(g)
29SM-K035U	1.8	UNI-POLAR	2.2	1.55	900	2.5	390	35	900
29SM-K138U	1.8	UNI-POLAR	2.6	1.25	1200	2.9	515	40	1180
29SM-K250U	1.8	UNI-POLAR	1.6	2	580	3.3	220	22	660
29SM-K379U	1.8	UNI-POLAR	1.9	1.75	820	3.0	330	30	820
29SM-K550U	1.8	UNI-POLAR	1.5	2.1	380	3.1	165	12	570
29SM-K711U	1.8	UNI-POLAR	3.0	1.0	1450	2.1	660	60	1390
29SM-K379B	1.8	BI-POLAR	1.3	3.6	1100	11	330	30	820
29SM-K711B	1.8	BI-POLAR	2.2	2	2100	8.3	660	60	1390

■トルク・スピード特性 Torque/Speed Characteristics

Motor Type: 29SM-K035U, K138U, K250U, K550U
Driver: Chopper Dual
Supply Voltage: 24 V (DC)

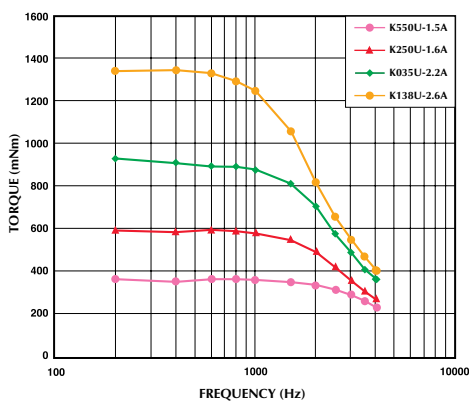

Motor Type: 29SM-K379U, K711U, K379B, K711B
Driver: Chopper Dual
Supply Voltage: 24 V (DC)

